

REVISIONS				
ZONE	REV.	DESCRIPTION	DATE	APPROVED
	A	PRELIMINARY	1/17/2014	MR

PRELIMINARY 01/17/14

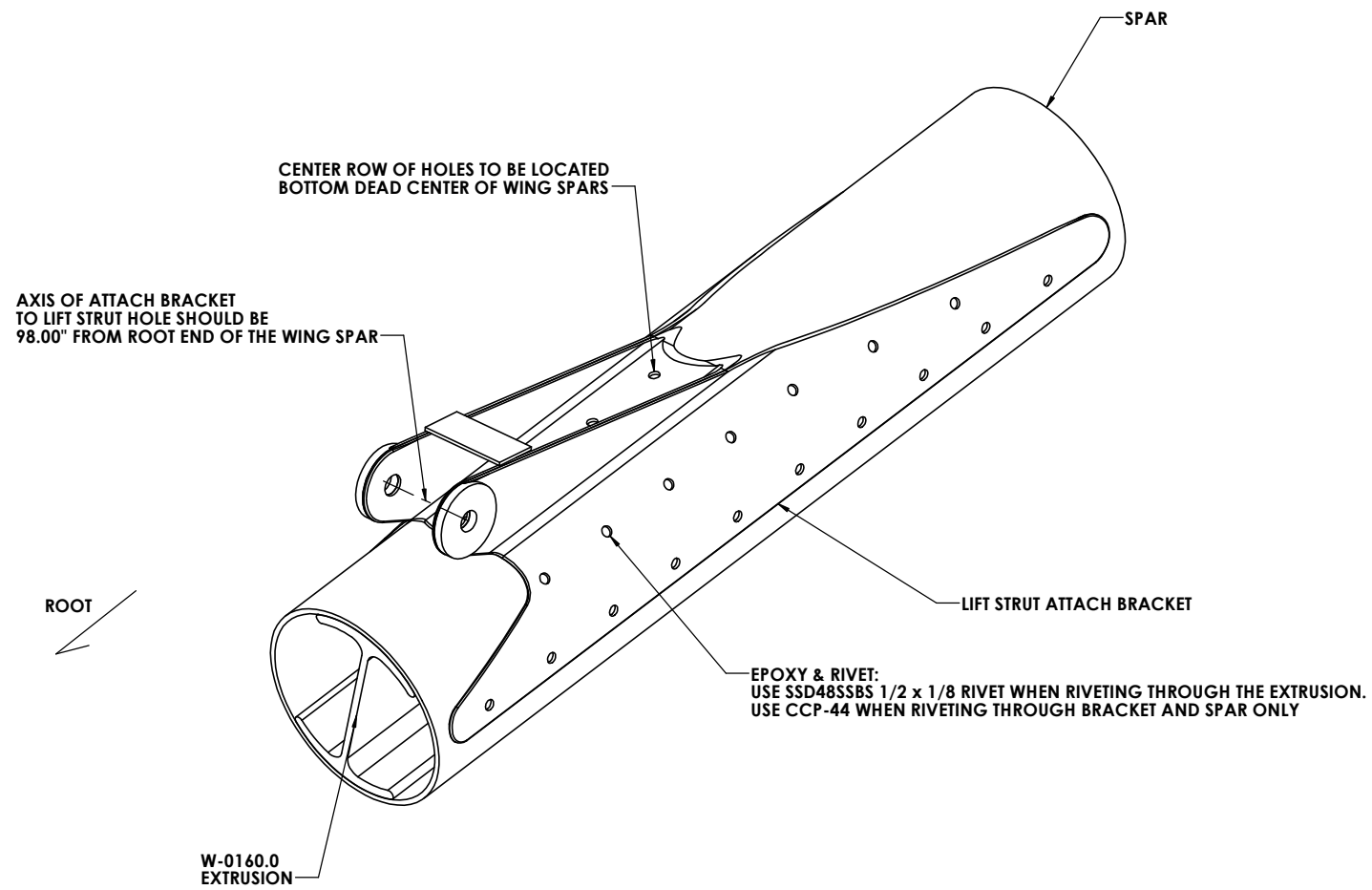

NOTES:
DRAWING FOR REFERENCE ONLY

LIFT STRUT ATTACH BRACKET

JUST AIRCRAFT, LLC	
WALHALLA, SOUTH CAROLINA 29691 USA	
DWG. NO.	REV
SE.1034	A
01/17/14	